



- Väikese kütusekuluga diiselmootor
- Kitsas ja kindel raam
- Eriti hea läbivusega
- 8 rattaga
- Mugav kabiin
- Tugev ja hea tõstuk
- Minimaalselt elektroonikat
- Lihtne hooldada

www.loader.cz



Mudel	LVS 511		
Mootor	Cummins		
Mootori tüüp	B 3.3T		
Mootori võimsus	57 kW / 2500 rpm		
Ülekanne	Hüdrovedu		
Sillavalem	8x8		
Hüdraulika Bosch Rexroth	Bosch Rexroth		
Silla lukud	Flow divider		
Kiirus	2 eri kiirust+potentiometer		
Rehvid	400/60-15,5 DT Forest		
Elektrisüsteem			
Vool	12 V		
Generaator	90 A		
Töötuled	8 x 70 W		
Kraana	MOWI P25	MOWI P30	Moheda M40
Noole pikkus [m]	5,2	5,7	6,5
Tõstevõime [kg]	420	450	450
Teleskoop	-	-	YES
Mõõdud			
Laius	1.860 mm		
Kõrgus	2.960 mm		
Pikkus	6.950 – 7.750 mm		
Kliirens	450 mm		
Masina kaal	4.475 – 5.500 kg olenevalt varustusest		
Kandevõime	5.000 kg		
Kabiin	Ruumikas ja turvaline hea nähtavusega . Pööratav operaatori pink, CD- raadio		
Suur valik lisavarustust.			

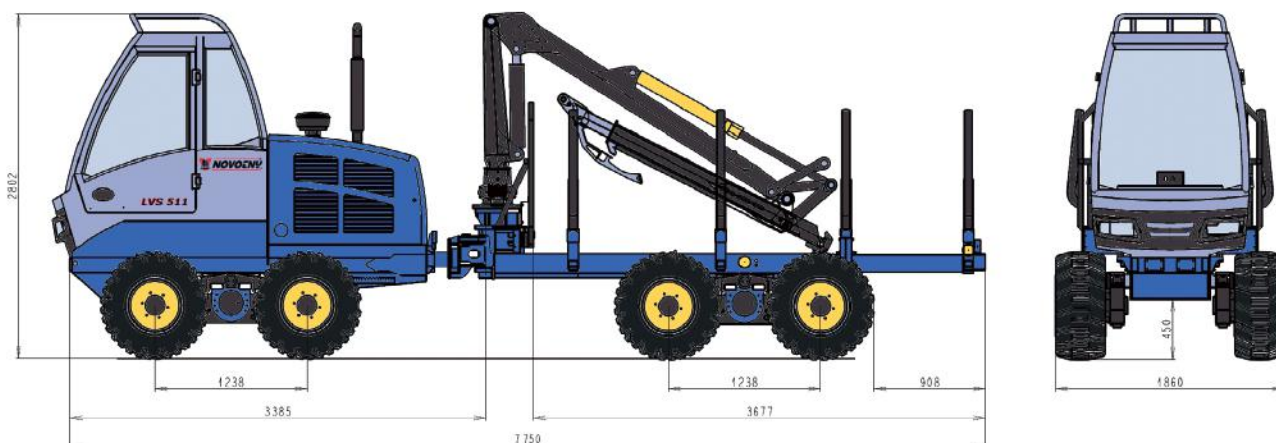

Strojnírna Novotný s.r.o.

Vitošov 50, 789 01 Hrabová | Czech republic

Phone/Fax +420 583 414 579 | Mob: +420 733 134 428 | Fax: +420 583 414 579

Email: novotny@loader.cz

www.loader.cz



Tarmo Kärbo +3725060300

Kert Kärbo +3725522755

www.takertrailers.ee

info@takertrailers.ee

